

| SERIES NO. | OPTIONAL SIDE SKINS | NOTES |
|------------|---------------------|---|
| BC3871 | SS3871 | |
| BC3880 | SS3880 | |
| BC4571 | SS4571 | |
| BC4580 | SS4580 | DOORS ARE NOT EQUIPT WITH FILTER CAGES. |
| BC5480 | SS5480 | BC5480 IS EQUIPT WITH 4 IN NUMBER TOP VENTILATION GRILLES. DOORS ARE NOT EQUIPT WITH FILTER CAGES. |

REFEREANCE DRAWING NUMBER 2006-12-102

VITALSINE BASE CABINET STANDARD CABINET CONFIGURATION COMPLETE WITH TOP VENTILATION GRILLES AND CONDUIT/CABLE ACCESS COVERS. FILTER CAGES SUPPLIED AND INSTALLED WITH THE BC3871, BC3880 AND BC4571 ONLY (FILTER CAGE INSERT OPTIONAL) ALL CABINET DOORS COMPLETE WITH LOCKING HANDLE. THE FRAME, TOP AND BOTTOM PAN OF THE VITALSINE BASE CABINET HAVE BEEN FORMED FROM 10 GAUGE STEEL SHEET. THE DOORS, SIDE AND BACK SKINS HAVE BEEN FORMED FROM 16 GAUGE STEEL SHEET, THE BASE COMPONENTS FORMED FROM 3/16" STEEL SHEET.
BASE CABINET AND ITS COMPONENTS HAVE BEEN POWDER COATED (MITSUBISHI BEIGE), OVEN BAKED FOR DURABILITY.

NOTE:
DOORS AND BACK SKIN SUPPLIED WITH THE BASE CABINET ARE NOT SHOWN, AS WELL AS THE OPTIONAL SIDE SKINS. SEE VITALSINE BASE CABINET, STANDARD CABINET CONFIGURATION.

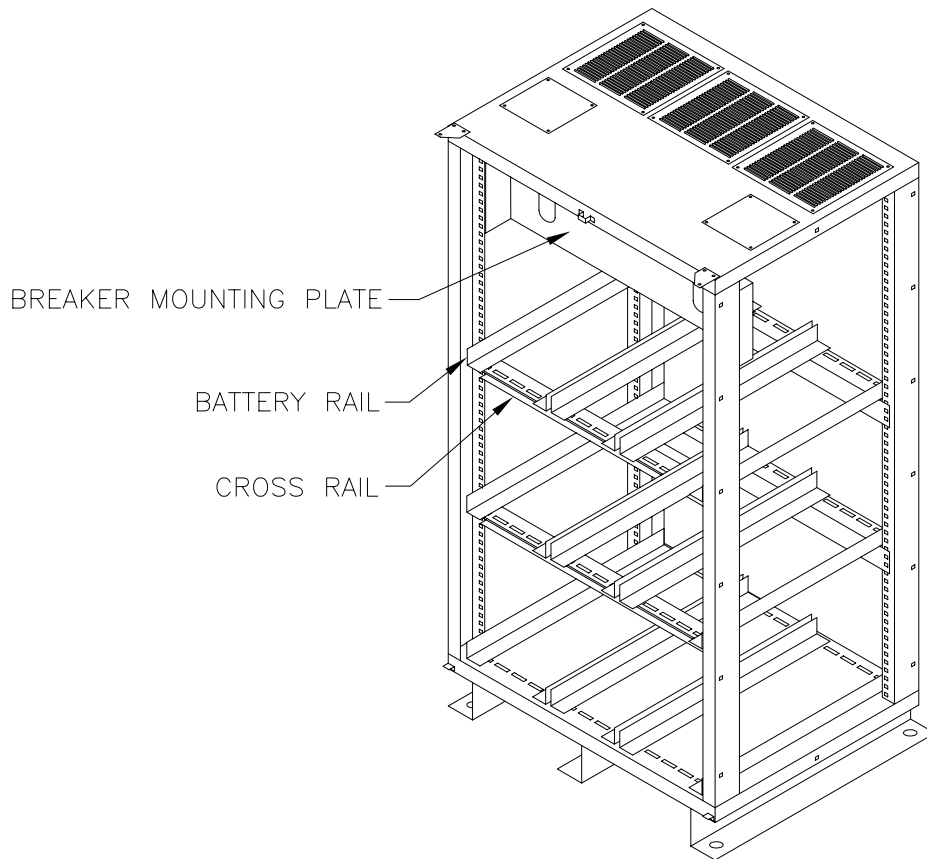

VITALSINE BASE CABINET,
BATTERY CABINET CONFIGURATION

| SERIES NO. | BREAKER MOUNTING PLATE | BATTERY RAIL (PAIR) | CROSS RAIL (PAIR) | NOTES |
|------------|------------------------|---------------------|-------------------|-------|
| BC3871 | BP38 | BR28-1 | CR38 | |
| BC3880 | BP38 | BR28-1 | CR38 | |
| BC4571 | BP45 | BR28-1 | CR45 | |
| BC4580 | BP45 | BR28-1 | CR45 | |
| BC5480 | BP54 | BR28-1 | CR54 | |

REFERENCE DRAWING NUMBER 2006-12-103

VITALSINE BASE CABINET BATTERY CABINET CONFIGURATION SEE VITALSINE BASE CABINET STANDARD CABINET CONFIGURATION FOR COMPONENT LISTING, SEE NOTE AT TOP OF PAGE.

BASE CABINET AND ITS COMPONENTS HAVE BEEN POWDER COATED (MITSUBISHI BEIGE), OVEN BAKED FOR DURABILITY.