



Server Technology, Inc.

Measuring Power & Efficiency in the “Green” Data Center

Using POPS™ (Per Outlet Power Sensing) and the
SPM™ (Sentry Power Manager)

White Paper STI-100-006

North America

Server Technology, Inc.
1040 Sandhill Drive
Reno, NV 89521
United States
+1 (775) 284-2000
sales@servertech.com
www.servertech.com
www.servertechblog.com

EMEA

Server Technology Intl.
Sienna Court
The Broadway
Maidenhead
Berkshire SL6 1NJ
United Kingdom
+44.1628.509053 Tel
salesint@servertech.com

APAC

Server Technology Intl.
37th Floor
Singapore Land Tower
50 Raffles Place
Singapore 048623
+65 (0) 6829 7008 Tel
+ 65 (0) 6234 4574 Fax
salesint@servertech.com

Per Outlet Power Monitoring

INTRODUCTION

Increasing powering and cooling demands within the data center have made these the topics of choice for Data Center (DC) and Facility Managers for several years now. Increased power demands are a result of the need for more compute power and the higher density devices that resulted. These high density installations include stacks and stacks of servers and the trend of implementing blade servers within these server "farms". Cooling problems are a direct result of these increased power demands based on the simple fact that more power increases the demand for cooling.

On December 20, 2006 Congress enacted Public Law 109-431: An Act to Study and Promote the Use of Energy Efficient Computer Servers in the United States. The act directed the EPA www.epa.gov to study and report back to Congress its findings by "analyzing the rapid growth and energy consumption of computer data centers by the Federal Government and private enterprise". The formal report released August 2, 2007 is available at www.energystar.com and had many notable findings:

- Data Centers (DC's) in the US (United States) consumed approximately 60 billion kilowatt-hours (kW-h) in 2006-roughly 1.5% of the nation's total electricity consumption.
- Servers and data centers energy consumption in the US doubled over the most recent 5 years and is expected to nearly double in the next five years to more than 100 billion kW-h
- Today's data centers account for approximately 7 gigawatts (GW) of peak load on the power grid. This is equivalent to about 15 base-load power plants. If the current trends continue the demand will rise to 12 GW by 2011, which will require the US to build an additional 10 power plants just to meet data center growth.

These increased demands for power and cooling combined with decreased power availability and increased power costs have convinced the data center industry that it makes good business sense to go "green". Energy costs have escalated enough that annual power costs are expected to exceed server acquisition costs by 2010 according to recent estimates. Some of the push to go green has not been solely based on good business but on the fact that the government has taken an interest in data centers. This interest in the data center market place is based on the huge amounts of power and

water being consumed by data centers today. The government helping the Information Technology (IT) industry reminds me of the old joke about the person that answers the door and the guy at the door says "I am from the government and I am here to help you!" Though businesses today are not overly concerned about new regulations that might hamper or change their operations the government coming to their rescue is a scary thought. In fact ENERGY STAR and the Department of Energy (DOE) are now working to make it easier for companies to increase their efficiency by providing measurement metrics, efficiency ratings on servers and information on how they compare with their peers at other DC facilities.

Based on this EPA report and other organizations like ASHRAE <http://www.ashrae.org/> (The American Society of Heating, Refrigerating and Air-Conditioning Engineers) the long term prediction is that demand for power and therefore cooling will continue to rise for at least the next several years.

To make better decisions, reduce power consumption and maximize each cabinet installation, more information is needed, per device, per application per cabinet, per groups of cabinets and per facility. The ability to monitor the current draw or power of an individual outlet within a Cabinet Power Distribution Unit as well as the voltage in-feed opens the door for significant opportunities to monitor and maximize efficiency, plan for future installations and determine the best location to allocate additional cooling resources. Monitoring power at the device level provides considerably more detailed information not obtained if the user were to monitor at the UPS, the floor PDU supplying power to the racks or at the breaker panel.

NEW METRICS AS PART OF THE DATA CENTER GREENING

As part of the Green movement there are new organizations being created and new standards being written to address these concerns. For example the familiar ENERGY STAR program is continuing to evolve to increase its roll in energy efficiency and Draft 2 for a new product specification for enterprise servers is posted and available for comment at www.energystar.gov. This specification is expected to be completed by the end of the year and in effect by January of 2009. Determining server efficiencies has been difficult in the past as it is directly related to the workload on each machine. Reference Article "Server Energy Measurement Protocol", Nov. 3, 2006.

There are existing metrics, guidelines and programs that address Data Center (DC) and IT energy efficiency. Below is a list of some of the more active organizations:

- 80 Plus program

- American Society of Heating, Refrigeration and Air-Conditioning Engineers (ASHRAE)
- Alliance for Telecommunications Industry Solutions (ATIS)
- Climate Savers Computing Initiative
- European Commission, Renewable Energies Unit, Code of Conduct on Data Centres
- Ecma
- EPA Energy Star
- Federal Energy Management Program
- LessWatts.org
- PG&E High Tech Energy Efficiency Incentive
- Server Energy Measurement Protocol
- Standard Performance Evaluation Corporation (SPEC)
- Storage Network Industry Association (SNIA)
- Space, Watts and Performance (SWaP)
- U.S. Green Building Council (USGBC)
- The Uptime Institute
- The Green Grid

This paper will focus on the newer metrics created by The Green Grid and The Uptime Institute. These organizations promote power measurement metrics and advocate power measurement points within the data center targeted at increasing data center efficiency. One organization that is very active and gaining the most steam within the industry is The Green Grid <http://www.thegreengrid.org/home>. In their white paper "**The Green Grid Data Center Power Efficiency Metrics: PUE and DCiE**", they advocate measuring the actual IT equipment power of the device. Similar papers and metrics have also emerged from The Uptime Institute <http://www.upsite.com/TUIpages/tuihome.html> like their paper "**Four Metrics Define Data Center "Greenness"**" where again one of the three key measuring points is at the hardware load at the device plug.

These metrics become even more significant as other organizations like the European Commission, Renewable Energies Unit which will formalize its Code of Conduct on Data Centres this year looked to organizations like The Green Grid when creating their standards. The Code of Conduct will focus on an IT Load and Facilities Load ratio as one of the key metrics in assessing efficiency. Currently there are no EU regulatory initiatives addressing the energy efficiency of data centres and the fact is it is very likely their metrics will resemble The Green Grid metrics making them relevant around the globe.

NEW METRICS DEFINED

THE GREEN GRID

The Green Grid understands how important it is to establish metrics for data center efficiency and provides metrics used for data center optimization. **The common theme heard over and over again is that you cannot improve something that you are not measuring.** To provide organizations with metrics that they can actually use The Green Grid has created two related metrics Power Usage Effectiveness (PUE) and Data Center Infrastructure Efficiency (DCiE).

The PUE is defined as follows:

PUE= Total Facility Power/IT Equipment Power

IT Equipment Power= This value is the load associated with all of the IT equipment, examples include servers, storage, network gear, and all supplemental equipment such as monitors and other devices like KVM's.

Total Facility Power= Includes all IT equipment power listed above plus everything that supports the IT equipment load. Examples include power delivery components like the Generators, UPS and Switch Gear. Cooling systems include the CRAC units (computer room air conditioning), pumps and cooling towers. All other components to make up the data center such as the lighting and the network and storage nodes.

DCiE is defined as follows:

DCiE= The reciprocal of the PUE

DCiE= $1/\text{PUE} = \text{IT Equipment Power}/\text{Total Facility Power} \times 100 = \text{ ______ } \%$

Both equations require the IT Equipment Power to be measured after all the power conversion, switching and conditioning is completed and before the IT equipment itself. The logical location is at the device plug and the logical device to make this measurement is the cabinet power distribution unit (PDU). New Cabinet PDU technology called POPS™ (Per Outlet Power Sensing) makes IT equipment power usage measurements available today. (See Figure 1, from The Green Grid recommending measurement right at the devices plug) These measurements can be made per device, application, cabinet, rows of cabinets or facility.

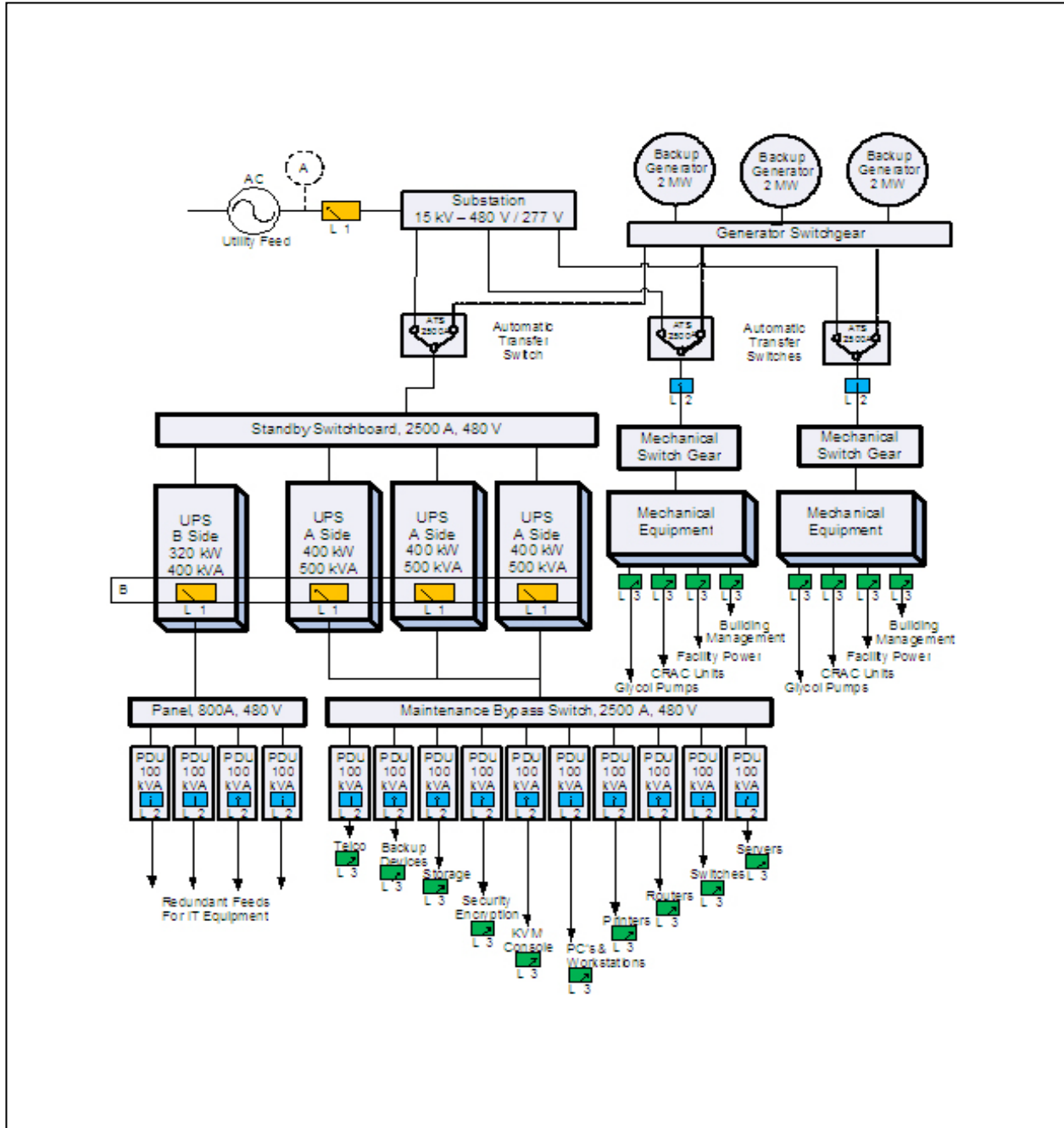

Figure 1: The Green Grids IT Equipment Measurement Recommendations (shown in Green)

Data center operators should aim for a PUE of less than 2 and ideally as close to 1 as possible. In other words, if you need 1,000 watts of power for IT equipment the data center should require no more than 2,000 W overall. Companies such as Microsoft have been monitoring PUE and have data going

back as far as 2004. They reference this metric in their fact sheet "Best Practices for Energy Efficiency in Microsoft Data Center Operations", February, 2008.

Metrics like PUE and DCiE allow the data center operator to compare results against other data centers and determine if any energy efficiency improvements need to be made. It should also be considered that the age and tier of the data center will also have some effect on the calculated metric results.

Some of the newer measurement parameters that The Green Grid is now working to address are the issue of productivity within the data center. This is a methodology for quantifying the useful work that a data center produces relative to the quantity of any resource that it consumes to produce this work. This DCeP (Data Center energy Productivity) metric is still in the early definition stage but expect to hear more about it in the future.

UPTIME INSTITUTE

The Uptime Institute provides metrics that enable energy and power consumption benchmarking and continuous improvement processes. Three of the four green metrics can be measured by the enterprise IT group. By using these three measurement parameters the data center can be broken down into IT strategy, asset utilization and hardware efficiency which enables the user to identify the areas with the greatest need for improvement.

The metrics that we are concerned with for this white paper are SI-POM (Site Infrastructure Power Overhead Multiplier) and H-POM (IT Hardware Power Overhead Multiplier). SI-POM is a dimensionless ratio that tells the data center operators how much of a data center's site power is consumed in over head instead of making it to the critical IT equipment. H-POM is also a dimensionless ratio which tells the data center operators how much of the power input to a piece of hardware is wasted in power supply conversion losses or diverted to internal fans, rather than making it to the components within the device.

SI-POM is defined as follows:

SI-POM= Data center power consumption at utility meter/Total hardware AC power consumption at the **plug** for all IT equipment

Data Center Power Consumption "at the Meter"- This is the total power consumption for the data center as measured at the utility meter or building sub-meter. It tells the data center operators how much power needs to be brought onto the site. This relates to everything including non-critical loads such as lights.

Hardware Load at the Plug- For a single device this is the power consumed measured at the power plug. Summed over all IT equipment in the data center it tells facility personnel how much power must be delivered by the UPS and PDU systems.

H-POM is defined as follows:

H-POM= AC Hardware Load at the **plug**/ Direct Current Hardware Compute Load

Hardware Compute Load- This value describes the number of Watts of direct current power that are consumed by the components within the IT equipment.

Both equations require the IT Equipment Power to be measured after all the power conversion, switching and conditioning is completed and before the IT equipment itself. The logical device to make this measurement is again the cabinet power distribution unit (PDU).

The Uptime Institute Data Center Electricity flow drawing (Figure 2) advocates **B*** as the practical measurement point for hardware load at the plug. Not realizing that there is technology available today to measure at **B** as the hardware load at the plug (true measurement) is the best location to make this measurement and provides the end user with the most accurate information.

NOTE: It is important to note here that The Green Grid and the Uptime Institute both recommend making the IT load measurement right at the device. The most intelligent device in the cabinet besides the servers and other connected devices is the Cabinet Power Distribution Unit that is powering it.

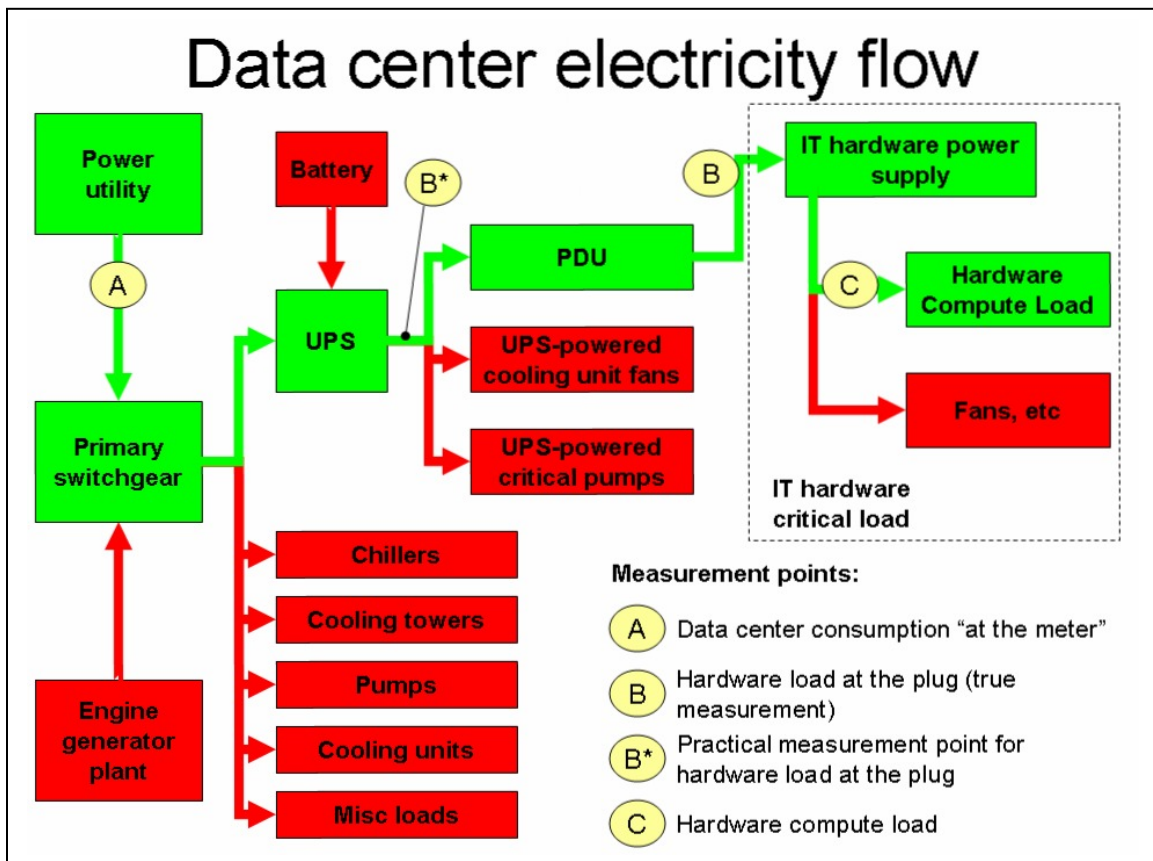

Figure 2: Uptime Institute Measurement Locations

MODERN PDU'S (SWITCHED CABINET POWER DISTRIBUTION UNITS)

Early PDU's did not offer a current load meter while today's zero U cabinet PDU's come complete with web interface, local and networked current monitoring, environmental measurements, networked reboot capabilities, SNMP traps and many other features that data centers take for granted today. Since the first PDU many advances have taken place on both the firmware and hardware portions of the product:

Firmware/software advances have included:

- Security such as SSL and SSH
- Automatic firmware updates via a ftp server
- Active directory services (LDAP and LDAPS)
- TACACS+
- Radius
- Logging

- Email alerts
- Outlet grouping
- DHCP support
- Smart Load Shedding
- Graceful server shutdown
- Sentry Power Manager (SPM) software to control and monitor multiple PDU's in multiple locations

Many of the recent hardware advancements have centered around high density applications with PDU's that support:

- Three phase power (208 V/480 V 3 Phase or 400 V 3-Phase Power)
- Higher current ratings meeting today's higher density requirements (30, 32 or 60 amp products)
- Multiple outlet types on a single PDU
- Multiple voltage outputs such as 120 V or 208 V coming from the same PDU
- Modular designs to support flexible installations
- Highly Accurate Digital TRMS current monitoring
- Per Outlet measurements of load (amps), voltage, active power (watts), apparent power (VA), Crest Factor and Power Factor

The new features and functions recently introduced focus on data centers' desire to not only monitor but also to control and manage their facilities to increase efficiency by making better and faster decisions when implementing new equipment or trying to solve a problem. Many of these features include the ability to calculate the total kW power load for all of the devices for a single PDU or for all of the devices in the cabinet. With the user inputting the size of the cabinet, the kW per square foot or per square meter of the cabinet can easily be determined. The voltage is measured at the in-feed and the current load is determined either per PDU, per phase or per outlet. Or for remote equipment cabinets or locations the ability upon the UPS losing power or at elevated temperatures for the PDU to shut off individual outlets attached to non-critical devices to keep the critical devices up and running as long as possible.

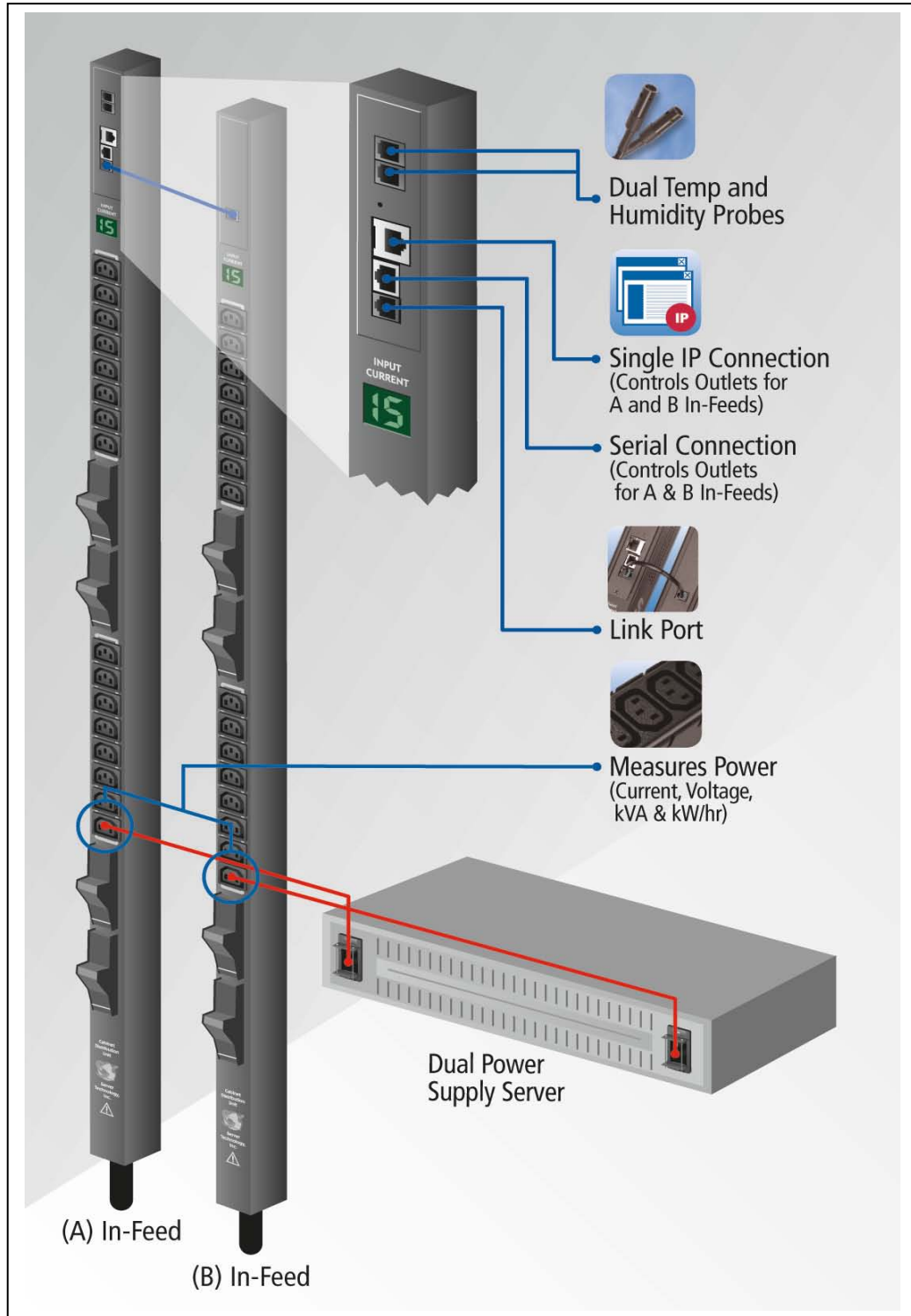

**Figure 3:
Per Outlet Power Sensing (POPS)
Measurements**

POPS (PER OUTLET POWER SENSING) WITH THE PDU'S INTEGRAL WEB INTERFACE:

Server Technology's recently released the POPS product (Figure 3) with measurement accuracy levels currently not available in the market today, it provides per outlet power sensing for each individual outlet for:

- Load (amps)
- Voltage (V)
- Active power (watts)
- Apparent power (VA)
- Crest Factor
- Power Factor

Though individual outlet information is interesting, it is the application of the POPS technology that provides the real value within the data center. For example, by using Server Technology's exclusive grouping feature the user can group outlets within a single IP address and across two power in-feeds so that kW's can easily be determined; for a device, a group of devices, an individual PDU or a cabinet. (See Figure 3) This information is directly aligned with The Green Grid and the Uptime Institutes recommendations of measuring the hardware load right at the plug or device.

This information can be used for:

- Calculating the PUE and DCiE from The Green Grid and the SI-POM and H-POM calculations recommended by The Uptime Institute.

- Confirming that a particular device is indeed turned off by looking at the current draw of a particular outlet

- Sending out an SNMP trap or email alert if the current draw on a particular outlet drops above or below a specified threshold and alerting the user that the devices power supply is damaged or that the device is idle and therefore a candidate to be turned off or virtualized

- Outlet grouping to calculate the amount of power a particular device, multiple devices or a specific application is using

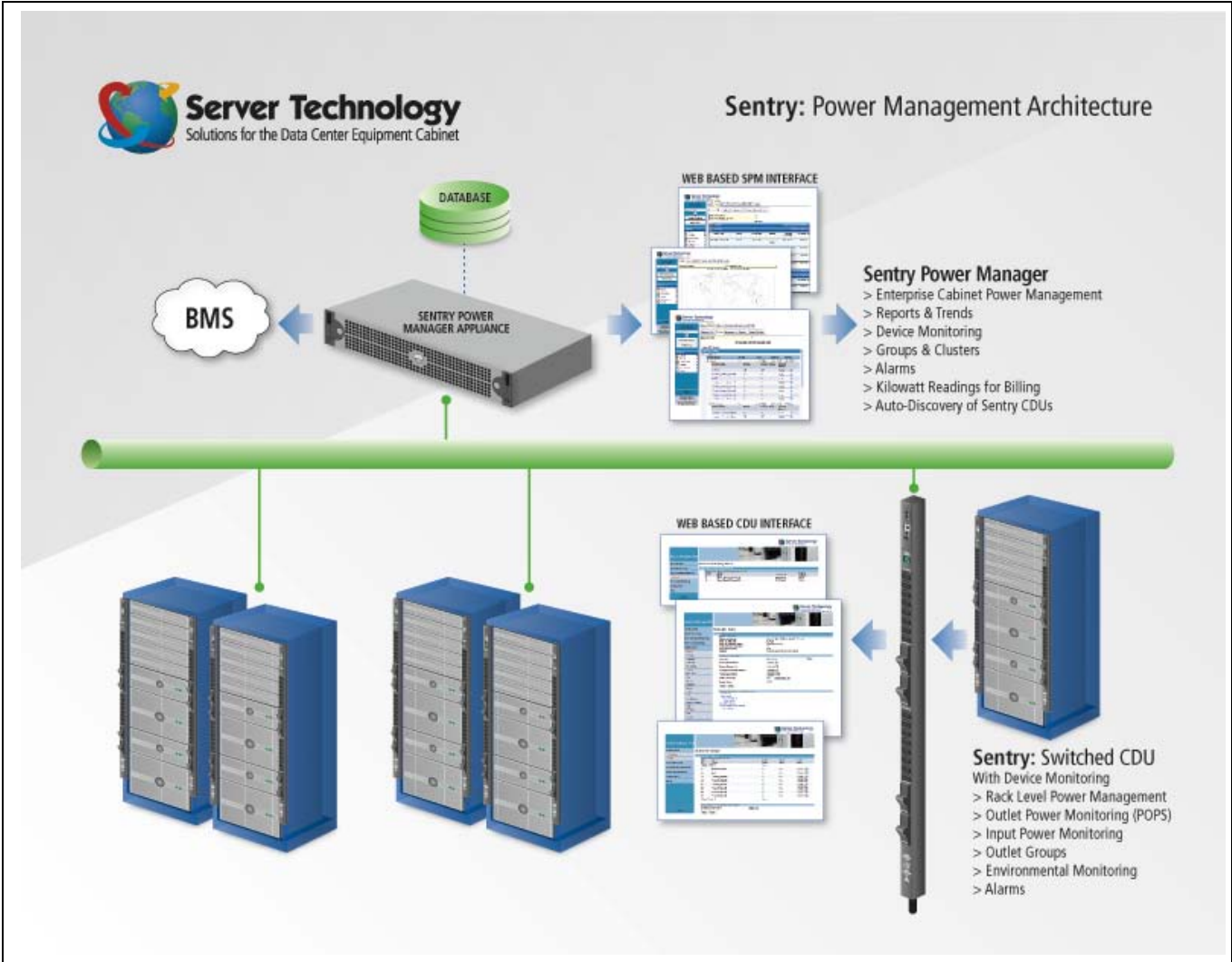

**Figure 4:
Sentry Power Management Architecture**

POPS AND THE SPM (SENTRY POWER MANAGER)

Operational costs of a data center have grown to the point that effectively managing this resource can make the difference between your organization performing better or worse than your closest competitor. The old story of a million dollars here and a million dollars there and pretty soon you are talking about some real money applies to power costs in the DC today. To determine how different parts of your organization are consuming resources and also how effectively these groups are utilizing those same resources

many companies now advocate that the each department is billed for the amount of power they use within the data center. This same thinking is also starting to apply in data center hosting or co-location facilities where the landscape is changing dramatically. Instead of how much space the user requires the conversation is now centered more on power density and kilowatts with much of the industry starting to move toward a tiered pricing model based on kilowatts required rather than just selling real estate. Though admittedly, this pricing approach may take time since the economics may not be in the hosted facilities favor.

Combining POPS technology with an integrated software solution such as the Sentry Power Manger (SPM) provides a number of benefits when operating and managing a data center:

- 1) Power information can be reported and provided per:
 - a) Outlet
 - b) Device (server or blade server with multiple power supplies)
 - c) Application (groups of devices)
 - d) Cabinet
 - e) Groups of Cabinet
 - f) Facility

*This grouping and clustering feature of power provides a number of unique features and functions.
- 2) This information can be used to calculate the PUE and DCiE from The Green Grid and the SI-POM and H-POM for The Uptime Institute
- 3) Not only can kW power information be provided but kW-h information can be provided and reported for power billing either in an Enterprise DC or a Co-Location facility
- 4) kW and kW-h information can be logged, graphed or exported to other third party Building Management Systems (BMS).
- 5) This power information can also be used for capacity planning to understand where there is available power or cooling for new equipment installations
- 6) Some facilities are also looking at power utilization to determine hot spots in their data center and to provide more dynamic cooling with their facilities
- 7) Knowing the actual amount of power being draw per circuit also allows each circuit to be maximized to ensure that the full value of that power circuit is being realized
- 8) Setting a low power threshold will allow the user to determine devices that are idle and therefore a candidate to be turned off or virtualized

Providing the kW-h per outlet, device, application, rack, rack/sq feet or rack/sq meter provides either the enterprise data center or the hosted facility with valuable information. The ability to graph, log and trend this information will allow the user to determine power and cooling requirements over a day, month or year.

Additional SPM Features:

- View your entire systems of PDU's from a global view down to the rack level
- Auto-Discover all PDU's on your network
- Logs include discovery, user logins, user actions and alarm status
- Graph (using start and end dates) temperature, humidity, in-feed load, in-feed power, system watts/unit area and system total power
- Simple and easy to understand alarm notification and acknowledgement
- Multiple views of status, current load, power, temperature, humidity and capacity

POPS technology combined with an Enterprise SW tool like the Sentry Power Manager provides detailed power information and the ability to properly monitor and manage at a device level. Integration of SPM with your Building Management System provides the Network Operations Center with critical information required by both facilities and the Data Center Manager to manage your DC facility.

OTHER WAYS TO INCREASE DATA CENTER EFFICIENCY

Companies committed to reducing their carbon footprint in their data centers are doing power/energy assessments and are finding many ways to save significant amounts of power. Some of the more common ways to save energy in the data center are:

- 1) Improving cooling efficiency using best practices
- 2) Virtualization
- 3) Turn-off idle IT equipment
- 4) Consolidation
- 5) Enable CPU power management feature on IT equipment
- 6) Purchase IT equipment with high efficiency power supplies
- 7) Use high efficiency UPS's
- 8) Adopt power distribution at 208/230 V or 400 V
- 9) Use The Green Grid and other metrics to calculate and monitor efficiency

One simple way to increase the efficiency in your data center by a few percentage points involves adopting power distribution at 208 volts. As there is a 2% efficiency gain just by going from to 120 V to 208 V power and a 3% efficiency gain going from 120 V to 230 V power with many devices. To determine what the gain is on your servers and other devices review the power supply specification and look at the efficiency % based on the various input voltages.

CONCLUSION

Power and cooling costs that are expected to increase, the possibility of increased regulations, customers requiring companies to act responsibly towards the environment and new tools and technology for determining efficiency are all driving companies to explore ways of making their data centers more environmentally friendly, "green" and more efficient. It is expected that this will be the trend as current power and cooling growth demand is not sustainable and in some locations DC facilities are being told by the local utility that they will not be given any more power. With these changes energy credits and rebates for virtualization or other projects will become more common and fuel more efficient Data Centers.

It is expected that organizations like The Green Grid will continue to drive global standards within the data center industry so that we are all speaking one language as the "green" trend gains focus and momentum within our industry.

Devices like Switched PDU's capable of making kW and kW-h power measurements of the IT load within a Data Center provide a significant advancement in the DC Manager's ability to determine the DC's efficiency. Calculating PUE and DCiE metrics are the first step to understanding power consumption and looking for ways to improve data center efficiency. Remember **"You cannot improve something that you are not measuring"**.